

10) COMPONENTES

10.1) LAI 400 P

ELITE(31)33914769

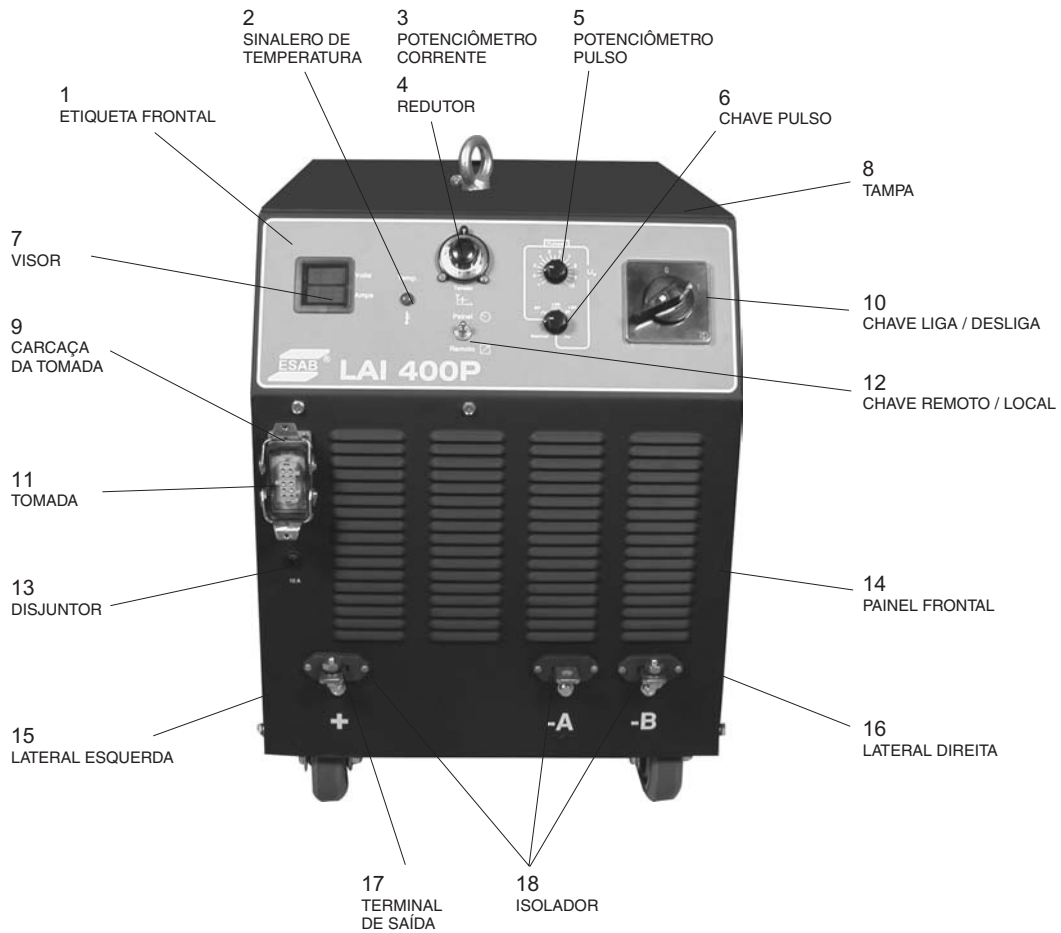

ELITE(31)33914769

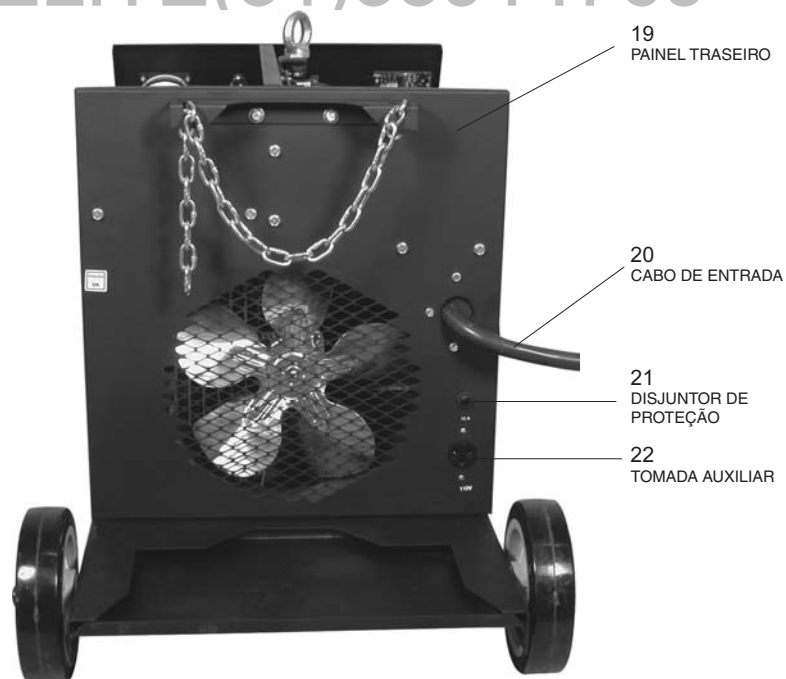

10.1) LAI 400 P

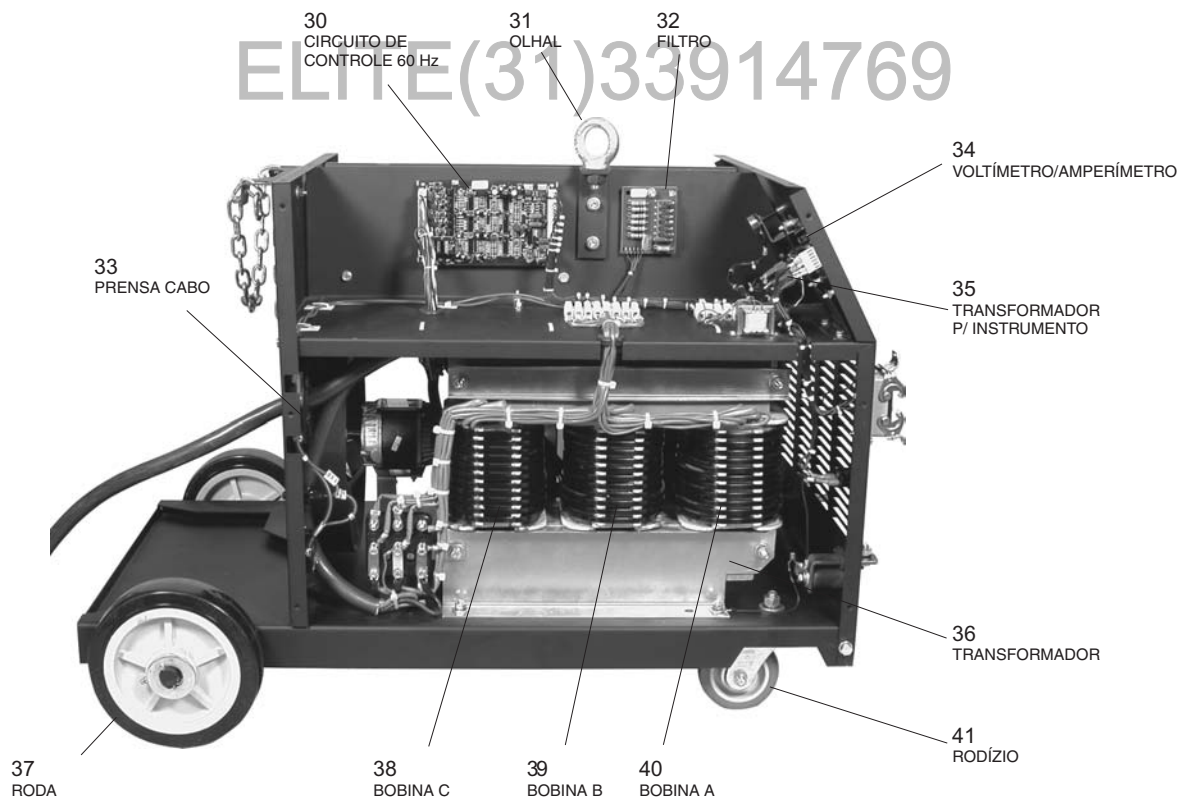
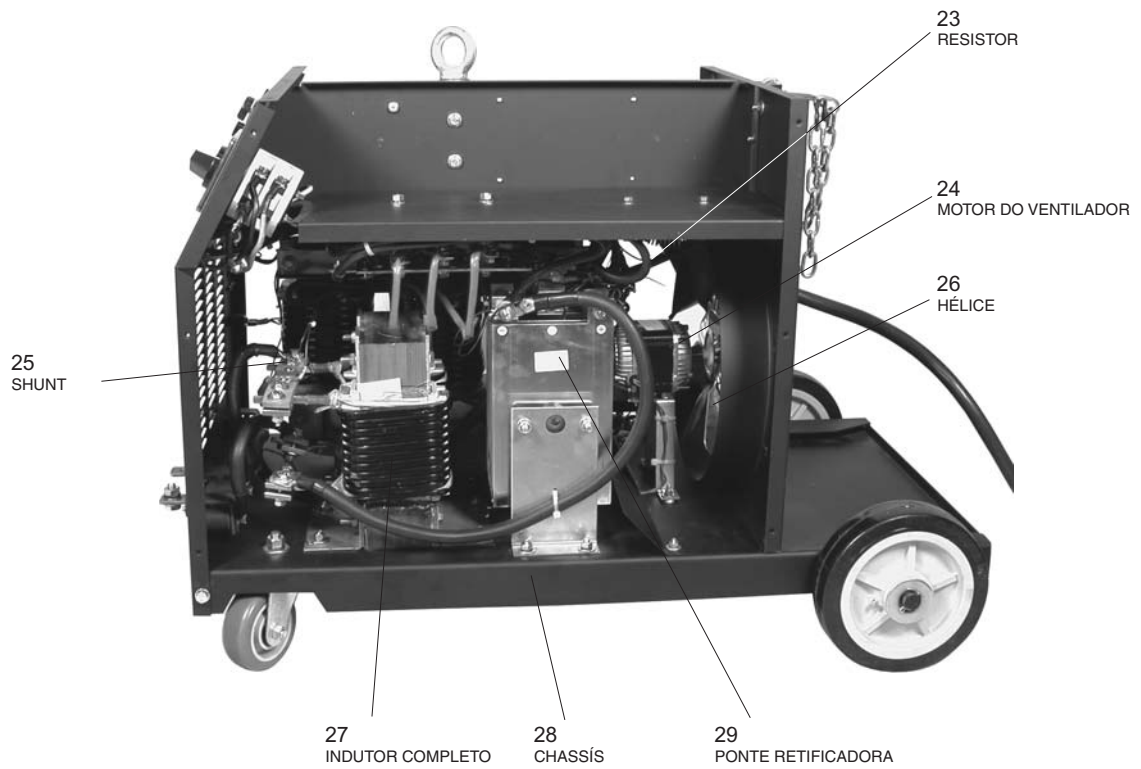

10.2) LAI 550 P

ELITE(31)33914769

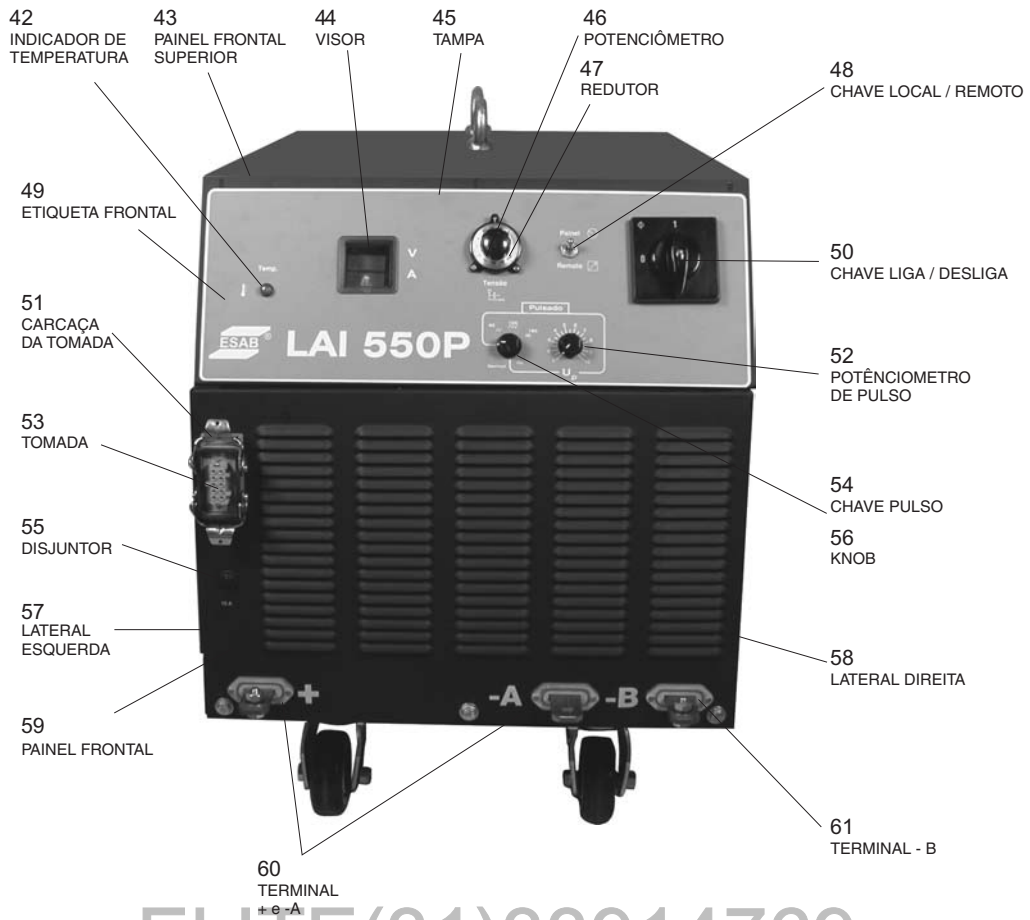

ELITE(31)33914769

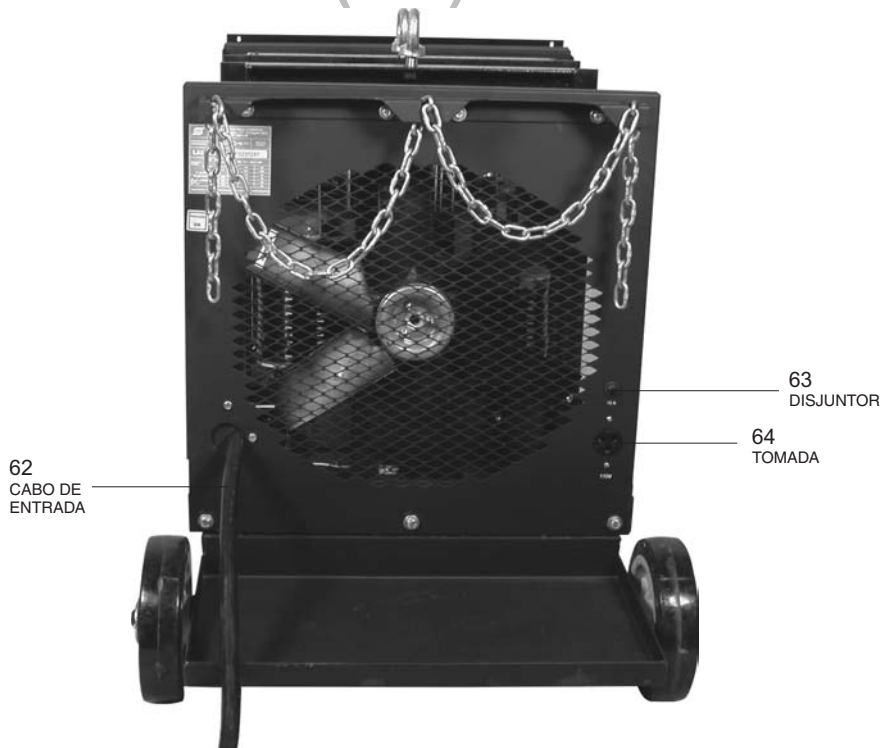

10.2) LAI 550 P

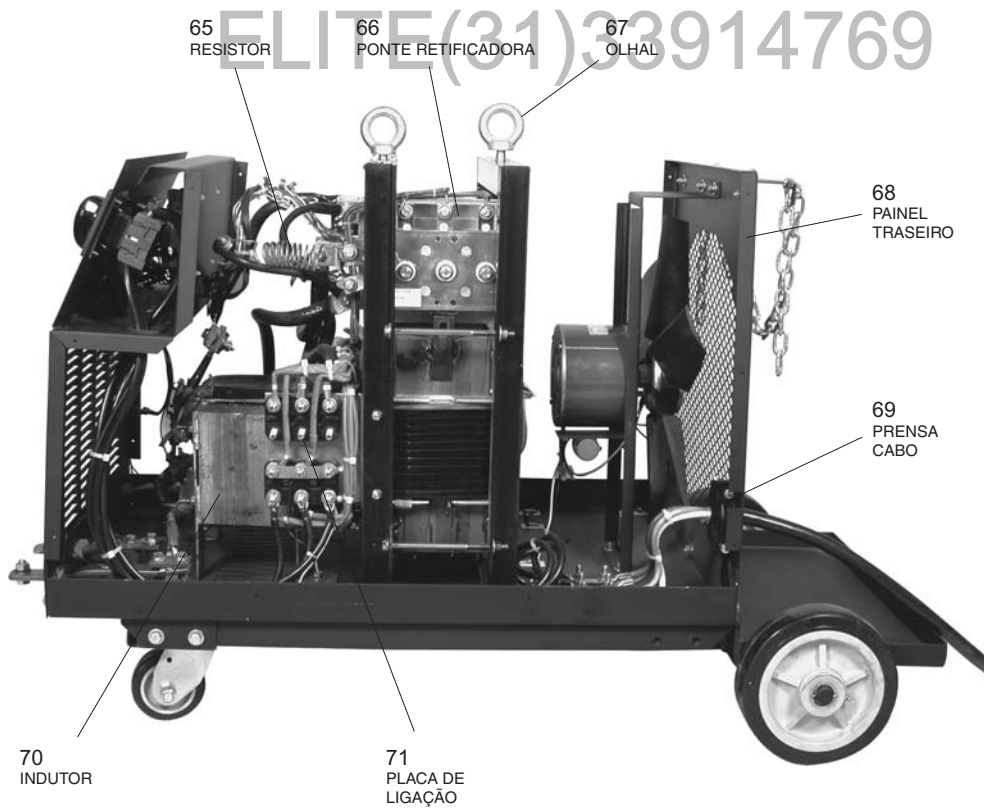

10.2) LAI 550 P

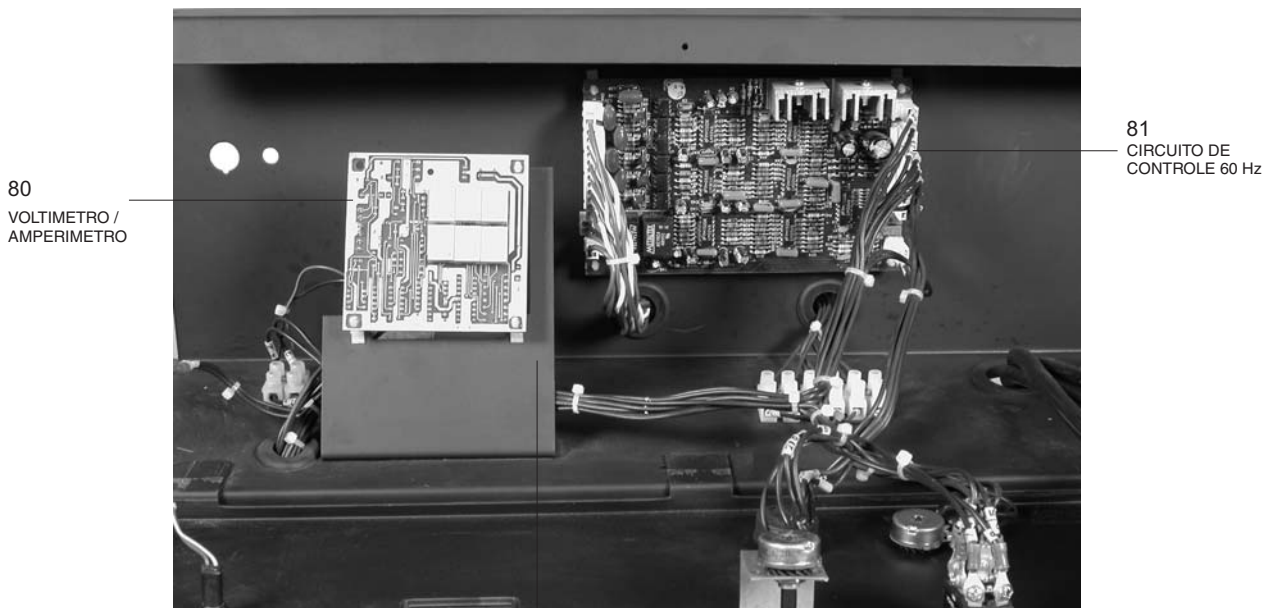

80
VOLTÍMETRO /
AMPÉRÍMETRO

81
CIRCUITO DE
CONTROLE 60 Hz

ELITE(31)33914769

82
TRANSFORMADOR
P/ INSTRUMENTO

TRANSFORMADOR
VISTA FRONTAL

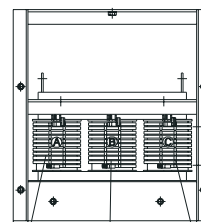

83 BOBINA A 84 BOBINA B 85 BOBINA C

11) ALIMENTADOR DE ARAME

TABELA 11.1

Descrição	Referência
MEF 30 R para arame até 1,6 mm	86
MEF 44 R para arame até 2,4 mm	87

ELITE(31)33914769

12) ACESSÓRIOS

TABELA 12.1

Descrição	Referência
Conjunto de cabos 400 A (02 m)	88
Conjunto de cabos 400 A (10 m)	89
Conjunto de cabos 400 A (15 m)	90
Conjunto de cabos 400 A (20 m)	91
Conjunto de cabos 550 A (02 m)	92
Conjunto de cabos 550 A (10 m)	93
Conjunto de cabos 550 A (15 m)	94
Conjunto de cabos 550 A (20 m)	95